

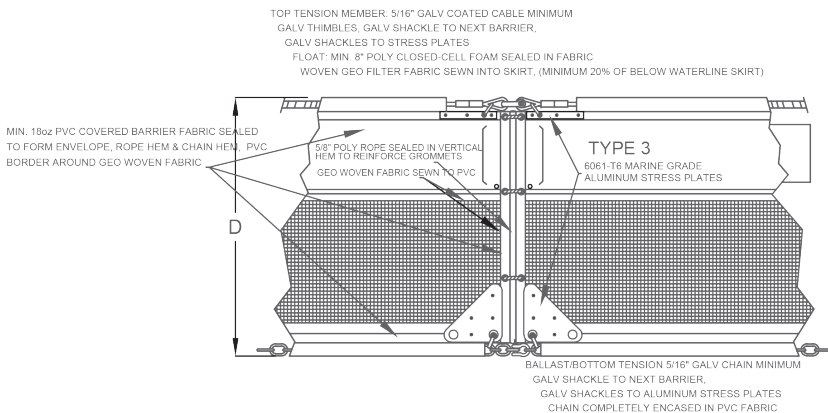

TURBIDITY BARRIERS

GENERAL DESIGN STANDARDS

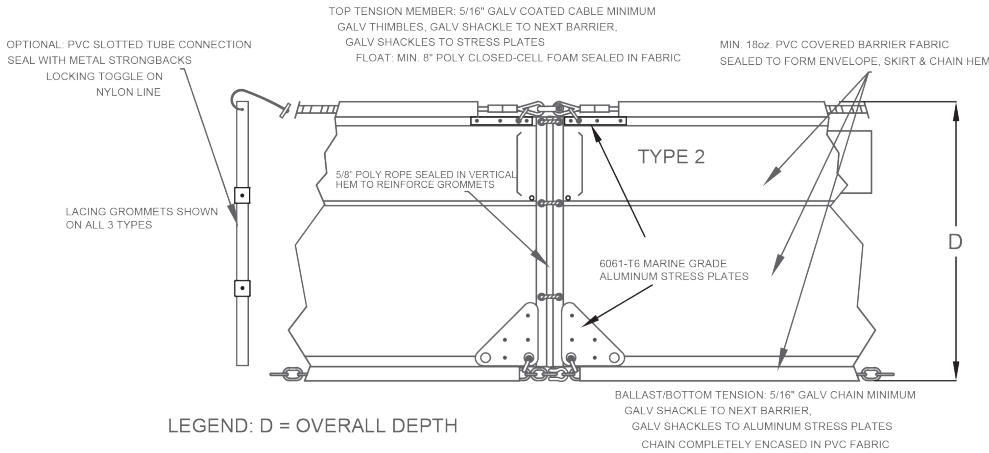
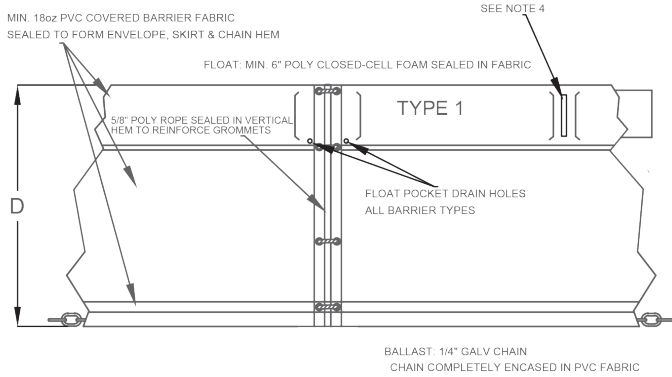

Notes:

1. Drawing not to scale
2. Barrier must have a minimum 4" freeboard
3. Floats, lacing grommet strip and ballast chain sealed in barrier fabric
4. Vertical seals between float segments
5. Overall depth to be specified by engineer
6. Barrier type and depth to be imprinted on float, min. 2 in lettering
7. 18 oz. Pvc covered barrier fabric minimum
8. Connections by lacing grommets, slotted tube or universal aluminum connector
9. Flotation sized for skirt depth/weight

SOLD ONLY BY AER-FLO DISTRIBUTORS

TURBIDITY BARRIERS

GENERAL DESIGN STANDARDS (continued)

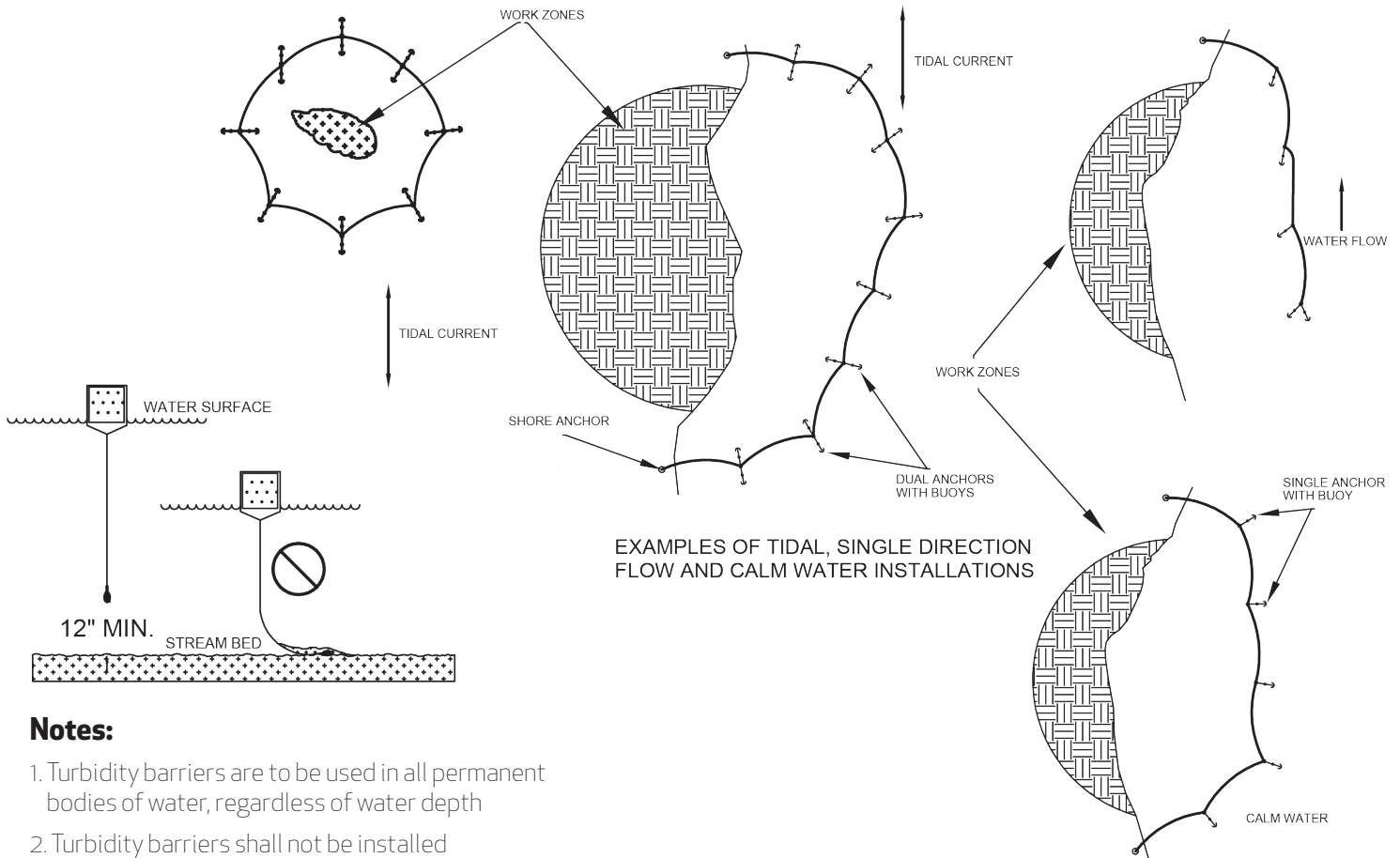

Notes:

1. Turbidity barriers are to be used in all permanent bodies of water, regardless of water depth
2. Turbidity barriers shall not be installed perpendicular to the main flow of a significant body of moving water
3. In areas of tidal flow, place buoyed anchors on opposite sides of the barrier to prevent barrier from overriding anchor on tide change
4. Do not anchor from bottom hem
5. Barrier must maintain a minimum 4 inch freeboard
6. Anchor spacing normally 100 ft, may need 50 ft spacing or larger anchors in areas of higher current
7. Shore anchors shall be of sufficient size, with deadman, if needed
8. Keep chain hem minimum 1 ft off bottom at low tide
9. Design of barrier and anchor systems shall be in accordance with manufacturer's specifications
10. Lighted buoys shall be used to meet regulatory standards

ANCHOR SYSTEM

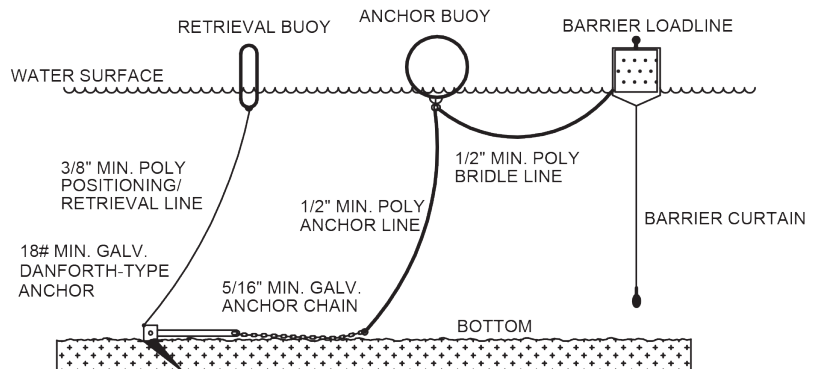

SOLD ONLY BY AER-FLO DISTRIBUTORS

PH: 941.747.4151 | AerFloEnv.com