



# CONNECTIONS FOR SILT CURTAINS

## GROMMET-TO-GROMMET: ROPE, BOLTS AND/OR CABLE TIES

**Type 1.DOT, Type 2.DOT and/or Type 3.DOT** curtains can also be connected by 3/8" bolts with fender washers and nylon-insert lock-nuts thru grommets (cadmium plated for short jobs or Stainless Steel for long) or short pieces of 3/8" poly, nylon or hemp line thru grommets and knotted around bolt-ropes.



**Type 2.DOT and Type 3.DOT Connections**  
The top cable will be shackled to the top cable, with vertical ends connected by high strength cable ties thru grommets and around bolt-ropes. All grommets are aligned barrier to barrier at nominal 12" spacing from float envelope seal.



**SOLD ONLY BY AER-FLO DISTRIBUTORS**

## PVC Slotted Tube Connection Seal

Slotted Tube Connection Seals are made from Schedule 40 PVC pipe with a slot cut all but the top 2" of the pipe. Aluminum collars are added as strong-backs to prevent the slot from expanding under pressure from the curtain after installation.

The slotted tubes are slipped down over the barrier ends which have 5/8" polyline bolt ropes reinforcing the fabric ends. The easiest way to do this is to put a piece of line thru the top grommets in the barriers to hold them back to back and slide the pipe down with the ropes inside the tube with just the two fabric thicknesses in the slot.

Some alignment of the bolt ropes below the tube may be necessary to get the tube as far down as it will go. The small rope at the top with the nylon toggle should then be laced thru the grommets to prevent the tube from sliding back up the connection. On curtains more than 5 feet deep, grommets are added just below the end of the slotted tube for securing the curtains the rest of the way down.

On a Type 1.DOT curtain, this completes the connection. On a Type 2.DOT or 3.DOT curtain, the top cables must be shackled together behind the PVC tube. The ballast chains at the bottom should then be shackled together if the curtains are of equal depth. On curtains of unequal depth, the ballast chains are NOT connected, but hang free.

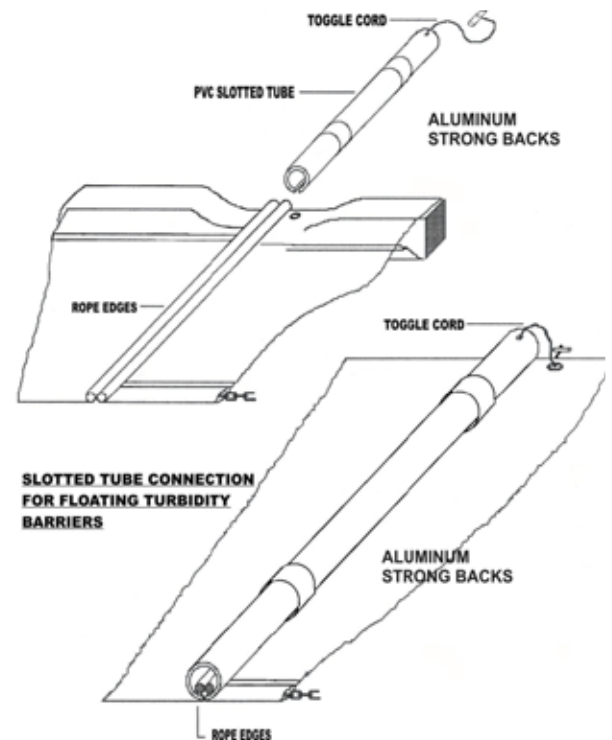

**SOLD ONLY BY AER-FLO DISTRIBUTORS**

# SILT CURTAIN

## CONNECTIONS (continued)



### ASTM Extruded Aluminum Connections (Z-Bar)

This type of end connector is made from extruded 6061-T6 marine grade aluminum with a tongue-and-groove profile to form a strong connection between curtain sections. The design was originally developed for quick connection of oil spill containment booms and then crossed over into use on silt curtains. It gained approval from ASTM, the American Society for Testing and Materials, as the standard connection for barriers.

The connections on barrier ends are interlocked and secured with two 3/8" stainless steel bolts with stainless nylon insert locking nuts. These connections are usually 24 to 36 inch high with the top cable on a Type 2.DOT or Type 3.DOT curtain shackled into the top of the aluminum connector. The curtain is attached to the connector by means of a back-up plate with 3/8" stainless steel bolts.

As with the PVC Slotted Tube Connection Seals, if the barrier has an overall depth greater than the connector, grommets will be found below the connector end for fastening the remaining skirt sections together with cable ties, ropes or bolts as described previously. ASTM connectors are available only from authorized manufacturers.

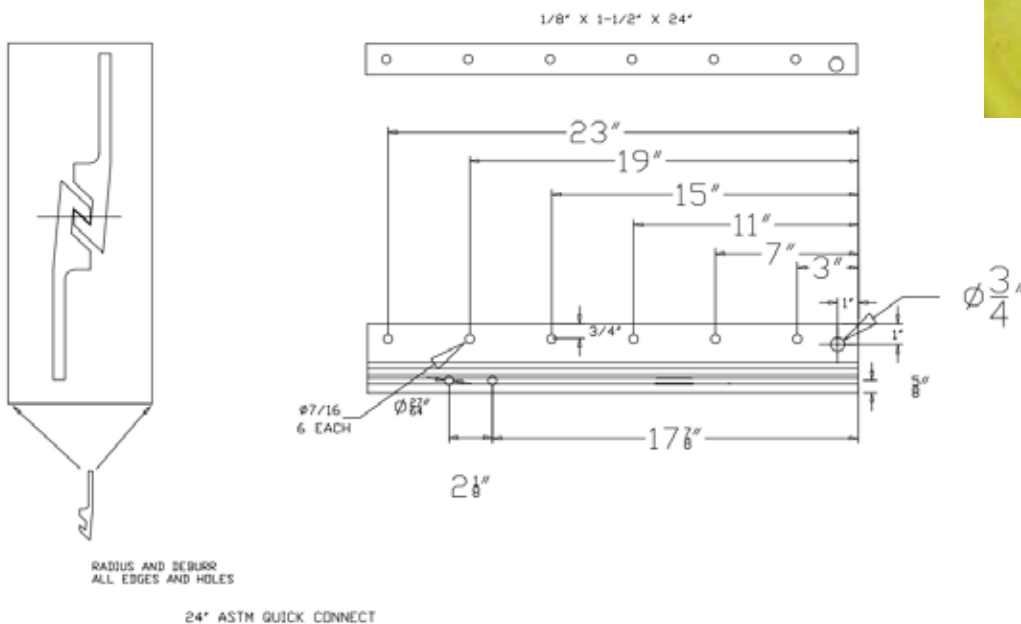

**SOLD ONLY BY AER-FLO DISTRIBUTORS**